

FRIDRO

ALL IN ONE PLACE

06/26

Nine⁹

posebna ponudba
ponudba velja do: 30.06.2026



GARNITURA:
orodje za graviranje

04



GARNITURA:
NC sveder + ploščica

04



GARNITURA:
ključ momentni
z nastavki

04



NC Spot Drill

- ▶ NC točkovni sveder z izmenljivo karbidno ploščico.
- ▶ Visoka učinkovitost! Nizki stroški!
- ▶ CNC stružnice, CNC stružni centri in obdelovalni centri.

Nine9®

- ▲ CNC stružnice
- a** Zunanje in notranje posnemanje robov
 - b** Izdelava utorov
 - c** Centriranje
 - d** Čelno struženje

Centriranje

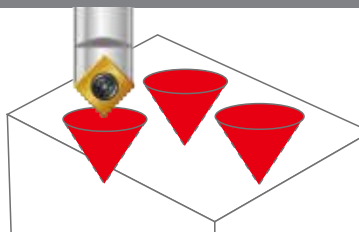

Posnemanje robov

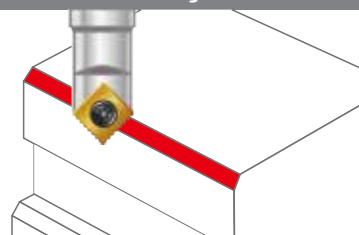

Izdelava utorov

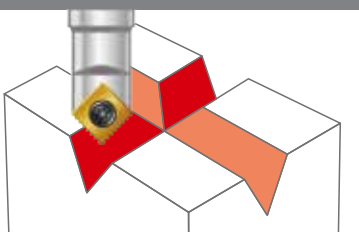

Graviranje

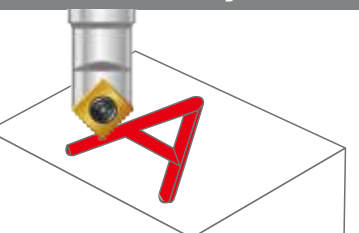

S centriranjem

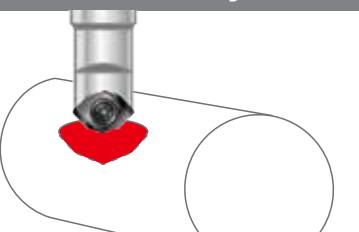

Zaokroževanje robov

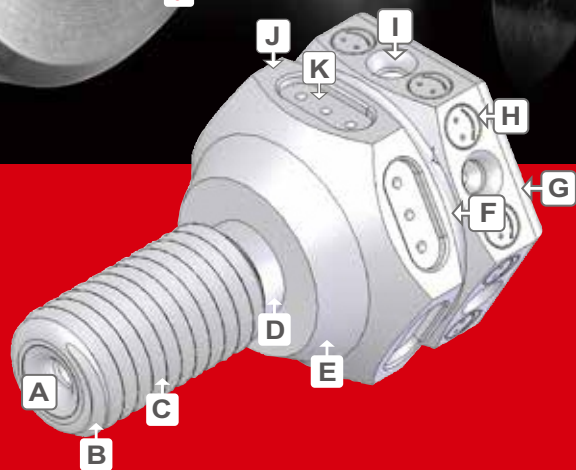
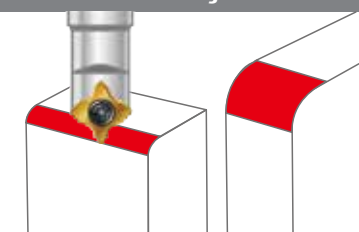

- Večnamensko:
- | | | | | | |
|----------|----------|---------------------------|----------|----------|---------------------|
| A | I | Centriranje | B | G | Zaokroževanje robov |
| C | | Struženje navojev | D | | Izdelava utorov |
| E | | Konusno struženje | F | | Izdelava V-utorov |
| H | | Graviranje | J | | Čelno rezkanje |
| K | | Vrtanje in rezkanje utora | | | |

* Določene obdelave so možne z uporabo posebne rezalne ploščice.

FRIDRO
ALL IN ONE PLACE



Prihranek stroškov



Prihranek časa



Visoko učinkovito



Dolga življenjska doba orodja

► Različne rezalne ploščice za isto držalo orodja



Nov koncept vrtnja! 0,5xD centriranja

NC centrni sveder	Brez centriranja	0.5xD centriranje	Večja centriralna izvrtina
<ul style="list-style-type: none"> Boljša natančnost centriranja! Daljša življenjska doba orodja! 	<ul style="list-style-type: none"> Manjša pozicijska natančnost in slabša toleranca premera. 	<ul style="list-style-type: none"> Najboljši rezultat! Višja hitrost in višji pomik. Boljša pozicijska natančnost in toleranca premera. 	<ul style="list-style-type: none"> Daljši čas centriranja! Vodenje na najšibkejšem delu rezalnega roba. Krajša življenjska doba orodja.

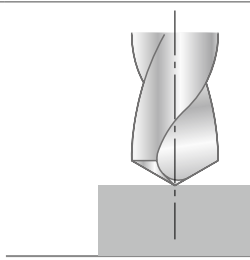

Nestabilna življenjska doba orodja

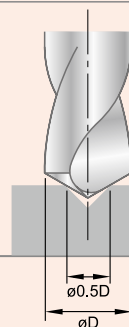

$\varnothing 0.5D$
 $\varnothing D$

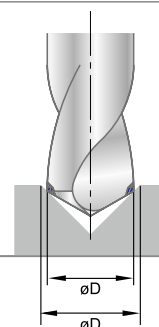

$\varnothing D$
 $\varnothing D$



GARNITURA: NC sveder + 6 ploščic

Začetni paket s svedrom in 6 ploščicami za vse tiste, ki želite poskusiti naprednejšo obdelavo z NC Spot Drill

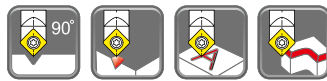

189,00
cena/GAR

NC sveder + 6 ploščic

NIŽJI STROŠKI!
VEČJA EKONOMIČNOST!



kat. št.	cena/GAR	DRŽALO 00-99616-14-12			PLOŠČICA N9MT11T3CT-NC40		
		koda	Ød	L	koda	kvaliteta	prevleka
604202-4401	189,00	604002	12	100	014401	P35	TiN

kat. št.	cena/GAR	DRŽALO 00-99616-14			PLOŠČICA N9MT11T3CT-NC40		
		koda	Ød	L	koda	kvaliteta	prevleka
604204-4401	189,00	604004	16	100	014401	P35	TiN



GARNITURA: orodje za graviranje

• Držalo, 3 ploščice in izvijač T7

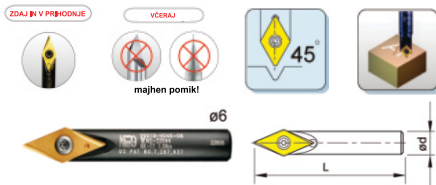

119,00
cena/GAR

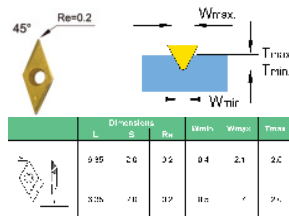

št. garniture	Ø vpetja mm	kot	L mm	cena/GAR	ploščice
00-99619-V045-03K-32 (691201-4502)	6	45°	40	119,00	V04506T1W06-2032
00-99619-V060-03K-32 (692201-6002)	6	60°	40	119,00	V06006T1W06-2032

GARNITURA: NC sveder + ploščica

- V garnituri: NC-sveder + ploščica
- 90°kot konice
- Ploščica za nekajena jekla in lito železo
- DIN 1835-B
- Za graviranje, NC navrtanje, posnemanje robov, plano struženje

Prednosti:

- Visoka učinkovitost! Nižji stroški!
- CNC stružnice, CNC stružni centri in strojni centri
- Eno orodje omogoča mnogovrstno obdelavo
- Dolga življenjska doba orodja
- Vsaka ploščica ima 4 rezne robove
- Primerne za na sliki opisane funkcije
- 45° / 60° / 82° / 90° / 100° / 120° / 142° koti za različne obdelave
- Zvišana rezalna hitrost s prevlečeno trakovinsko ploščico

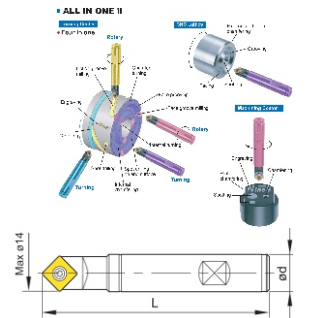

79,90
cena/GAR



št. garniture	cena/GAR	Ø vpetja mm	skupna dolžina mm	D max mm	ploščica
99000313 (604002)	79,90	12	100	14	N9MT11T3CT-NC40 (014401)
99000314 (604004)	79,90	16	100	14	N9MT11T3CT-NC40 (014401)

GARNITURA: ključ momentni z nastavki

Garnitura zajema:

- TPK-H01 - univerzalni T-ključ, primeren za vrtilni moment 0,6-5,5 Nm
- TPK-H02 - tanko, ergonomično držalo za natančno in učinkovito privijanje in odvijanje manjših vijakov, primeren za vrtilni moment 0,6-2,0 Nm
- Adapterji so iz ogljikovega jekla, HRC: 43-48, ponikljani in z magnetom
- Izmenljivi nastavki, HRC: 58-60

TORX



O-TPK01-TGTX-12K

od: **149,00**
cena/GAR

TORX PLUS



O-TPK02-TGIP-12K

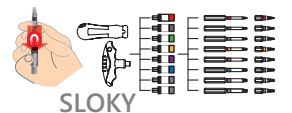

SLOKY



DRŽALO	cena/GAR	velikost	ADAPTER Nm	kgfcm	NASTAVKI dolžina 25 mm + 50 mm
TPK-H01 + TPK-H02	149,00	Tx6	0,6	6,1	1 kos + 1 kos
		Tx7	0,9	9,2	1 kos + 1 kos
		Tx8	1,2	12,0	1 kos + 1 kos
		Tx9	1,4	14,0	1 kos + 1 kos
		Tx10	2,0	20,4	1 kos + 1 kos
Tx15	3,0	30,6	1 kos + 1 kos		

DRŽALO	cena/GAR	velikost	ADAPTER Nm	kgfcm	NASTAVKI dolžina 25 mm + 50 mm
TPK-H01 + TPK-H02	155,00	6IP	0,6	6,1	1 kos + 1 kos
		7IP	0,9	9,2	1 kos + 1 kos
		8IP	1,2	12,0	1 kos + 1 kos
		9IP	1,4	14,0	1 kos + 1 kos
		10IP	2,0	20,4	1 kos + 1 kos
15IP	3,0	30,6	1 kos + 1 kos		